

2SK3690-01

N-CHANNEL SILICON POWER MOSFET

FUJI POWER MOSFET Super FAP-G Series

Features

- High speed switching
- Low on-resistance
- No secondary breakdown
- Low driving power
- Avalanche-proof

Applications

- Switching regulators
- DC-DC converters
- UPS (Uninterruptible Power Supply)

Maximum ratings and characteristic

● Absolute maximum ratings
(T_c=25°C unless otherwise specified)

Item	Symbol	Ratings	Unit	Remarks
Drain-source voltage	V _{DS}	600	V	
	V _{DSX}	600	V	V _{GS} =-30V
Continuous Drain Current	I _D	4.5	A	
Pulsed Drain Current	I _D (puls)	±18	A	
Gate-Source Voltage	V _{GS}	±30	V	
Maximum Avalanche current	I _{AR}	4.5	A	Note *1
Non-Repetitive Maximum Avalanche Energy	E _{AS}	261.1	mJ	Note *2
Repetitive Maximum Avalanche Energy	E _{AR}	8	mJ	Note *3
Maximum Drain-Source dV/dt	dV _{DS} /dt	20	kV/μs	V _{DS} ≤600V
Peak Diode Recovery dV/dt	dV/dt	5	kV/μs	Note *4
Max. Power Dissipation	P _D	80	W	T _c =25°C
		2.02		T _a =25°C
Operating and Storage Temperature range	T _{ch}	+150	°C	
	T _{stg}	-55 to +150	°C	

Outline Drawings (mm)

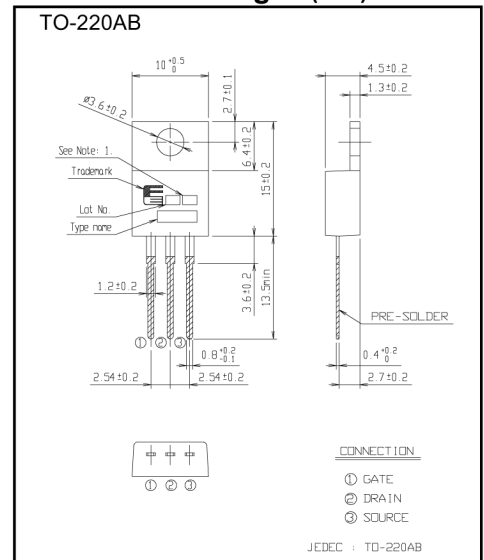

Equivalent circuit schematic

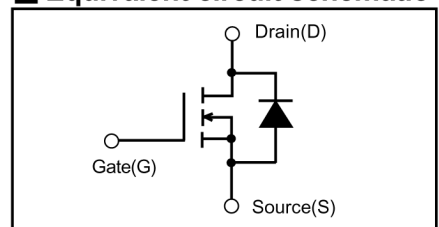

Note *1: T_{ch} ≤ 150°C, Repetitive and Non-repetitive

Note *2: Starting T_{ch}=25°C, I_{AS}=1.8A, L=148mH,

V_{CC}=60V, R_G=50Ω

E_{AS} limited by maximum channel temperature and Avalanche current.

See to the 'Avalanche Energy' graph

Note *3: Repetitive rating: Pulse width limited by maximum channel temperature.

See to the 'Transient Thermal impedance' graph.

Note *4: I_F ≤ -I_D, -di/dt = 50A/μs, V_{CC} ≤ BV_{DSS}, T_{ch} ≤ 150°C

Electrical characteristics (T_c = 25°C unless otherwise specified)

Item	Symbol	Test Conditions	Min.	Typ.	Max.	Units
Drain-Source Breakdown Voltage	BV _{DSS}	I _D =250μA V _{GS} =0V	600			V
Gate Threshold Voltage	V _{GS(th)}	I _D =250μA V _{DS} =V _{GS}	3.0		5.0	V
Zero Gate Voltage Drain Current	I _{DSS}	V _{DS} =600V V _{GS} =0V			25	μA
		V _{DS} =480V V _{GS} =0V			250	μA
Gate-Source Leakage Current	I _{GSS}	V _{GS} =±30V V _{DS} =0V		10	100	nA
Drain-Source On-State Resistance	R _{DS(on)}	I _D =2.25A V _{GS} =10V		1.8	2.3	Ω
Forward Transconductance	g _{fs}	I _D =2.25A V _{DS} =25V	2.5	5		S
Input Capacitance	C _{iss}	V _{DS} =25V		400	600	pF
Output Capacitance	C _{oss}	V _{GS} =0V		60	90	pF
Reverse Transfer Capacitance	C _{rss}	f=1MH		3	5	pF
Turn-On Time t _{on}	td(on)	V _{CC} =300V		18	27	ns
	t _r	I _D =2.25A		4	6	ns
Turn-Off Time t _{off}	td(off)	V _{GS} =10V		30	45	ns
	t _f	R _{GS} =10Ω		5	7.5	ns
Total Gate Charge	Q _G	V _{CC} =300V		15	23	nC
Gate-Source Charge	Q _{GS}	I _D =4.5A		5.5	8	nC
Gate-Drain Charge	Q _{GD}	V _{GS} =10V		3	4.5	nC
Diode forward on-voltage	V _{SD}	I _F =4.5A V _{GS} =0V T _{ch} =25°C		1.00	1.50	V
Reverse recovery time	t _{rr}	I _F =4.5A V _{GS} =0V		0.7		μs
Reverse recovery charge	Q _{rr}	-di/dt=100A/μs T _{ch} =25°C		3.5		μC

Thermal characteristics

Item	Symbol	Test Conditions	Min.	Typ.	Max.	Units
Thermal resistance	R _{th(ch-c)}	channel to case			1.563	°C/W
	R _{th(ch-a)}	channel to ambient			62	°C/W